



June 23, 2020

REQUEST FOR QUOTATIONS

The Philippine Department of Tourism-Korea is in need of the services of a well-experienced company based in Korea engaged in office design and set-up for the installation of office desk partition and storage cabinet at the Philippine Showroom.

Interested companies may submit designs and quotation following the attached Terms of Reference on June 27, 2020, 5:00 pm to:

Philippine Department of Tourism-Korea
Suite 801, President Hotel, Euljiro1-ga
Jung-gu, Seoul 04533 Korea
Tel no: (02) 598-2290 Fax: (02) 318-0520
Email: pdot@philippinetourism.co.kr and lily@philippinetourism.co.kr

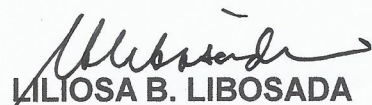
LILIOSA B. LIBOSADA
Senior Tourism Operations Officer
PDOT-Korea

TERMS OF REFERENCE

I. PROJECT TITLE: INSTALLATION OF OFFICE DESK PARTITION AND STORAGE CABINET FOR PHILIPPINE SHOWROOM

DATE: June 2020

VENUE: PHILIPPINE SHOWROOM

II. SCOPE OF WORK / DELIVERABLES

The Philippine Department of Tourism-Korea is in need of the services of a well-experienced company based in Korea engaged in office design and set-up for the installation of office desk partition and storage cabinet at the Philippine Showroom.

Following are the deliverables and specifications required by the Philippine Department of Tourism:

1. Partition matching the color of the existing desk

1 set - (PVC 45t, Wood and Glass)
- size: 4.38M x 1.2M(H)

2. Cabinet 1 set (wood) with graphics

- size: 6.0M x 0.4M x 0.8M(H)

Note: design will be subject to PDOT-Korea's approval prior to final preparation and setup.

III. TIME FRAME AND SCHEDULE OF WORK

Schedule: All interested parties to submit working design drawings and cost schedules within five (5) days after posting of this document.

June 27, 2020 (5:00 pm)	- Deadline of submission of design and budget
June 28 -29, 2020	- Design preparation and approval
June 30, 2020	- Setup and turnover

IV. BUDGET

Total budget allocation is KRW 4,500,000



[TOP VIEW]



[FRONT VIEW]

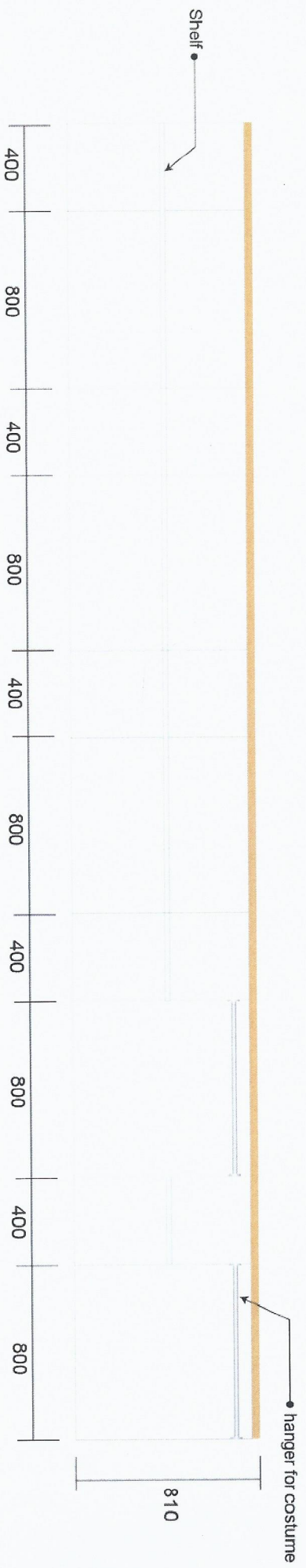

[INSIDE VIEW]

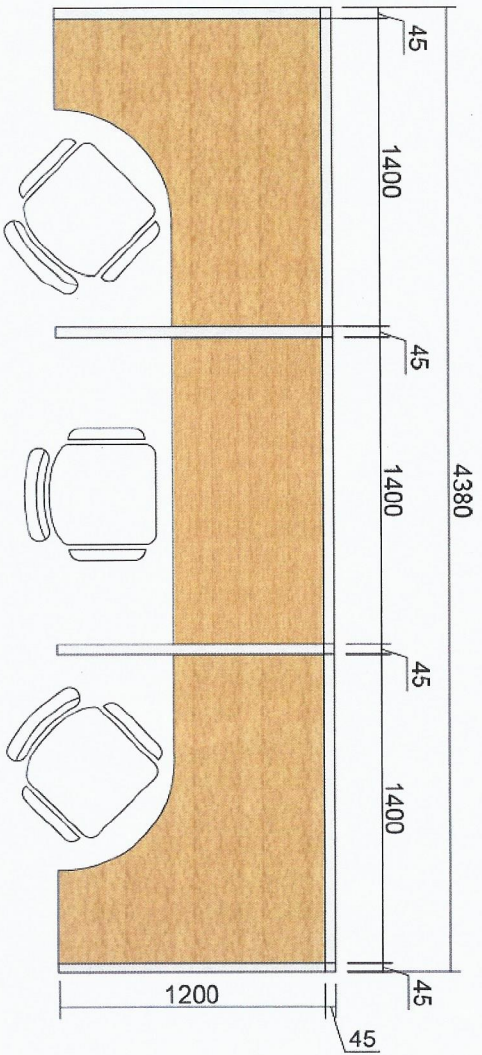

[TOP VIEW]

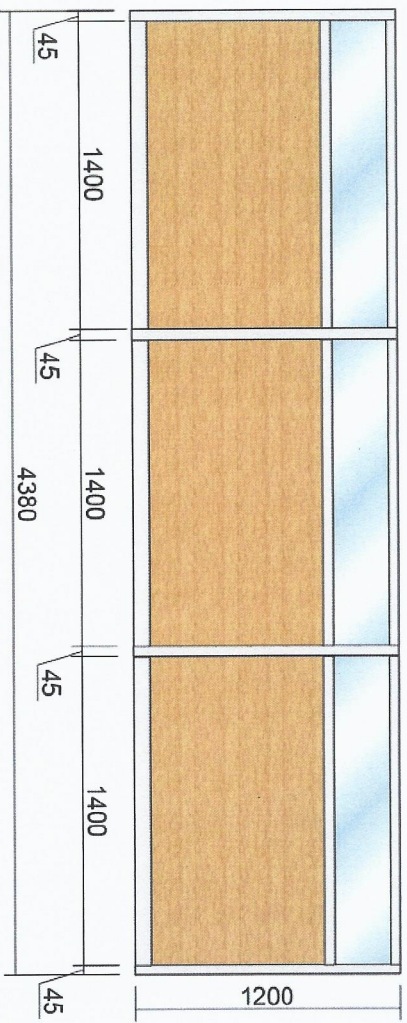

[FRONT VIEW]

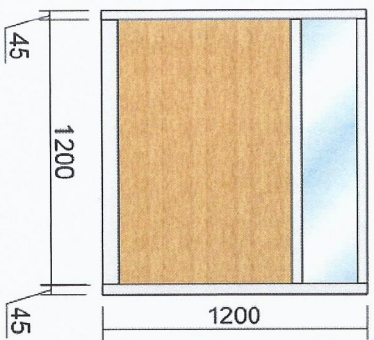

[SIDE VIEW]